

THREE TERMINAL POSITIVE VOLTAGE REGULATORS 5V, 6V, 7V, 8V, 9V, 10V, 12V, 15V, 18V, 20V, 24V.

FEATURES

- Internal Thermal Overload Protection.
- Internal Short Circuit Current Limiting.
- Output Current up to 1.5A.
- Satisfies IEC-65 Specification. (International Electronical Commission).
- Package is TO-220AB

LINE-UP

ITEM	OUTPUT VOLTAGE (Typ.)	UNIT
KIA7805AP	5	V
KIA7806AP	6	
KIA7807AP	7	
KIA7808AP	8	
KIA7809AP	9	
KIA7810AP	10	
KIA7812AP	12	
KIA7815AP	15	
KIA7818AP	18	
KIA7820AP	20	
KIA7824AP	24	

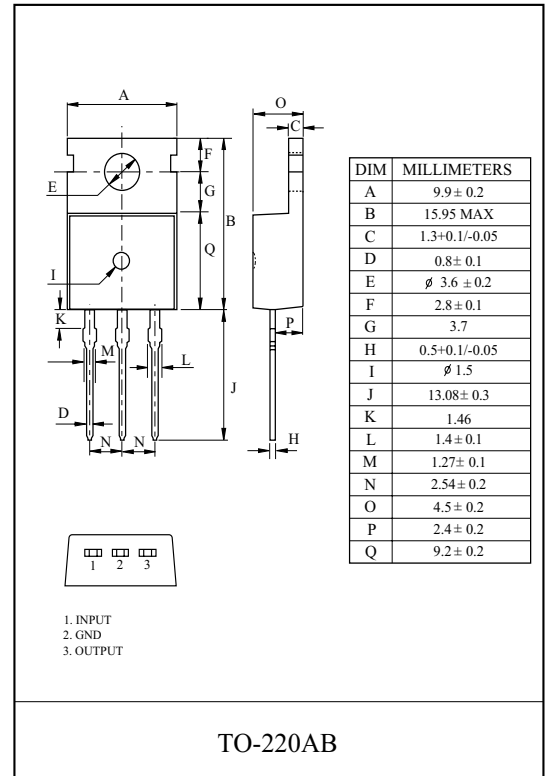

MAXIMUM RATINGS (Ta=25 °C)

CHARACTERISTIC		SYMBOL	RATING	UNIT
Input Voltage	KIA7805 ~ KIA7815	V_{IN}	35	V
	KIA7818 ~ KIA7824		40	
Power Dissipation-1 (No Heatsink)	AP	P_{D2}	1.9	W
Power Dissipation-2 (Infinite Heatsink)	AP	P_{D2}	30	
Operating Junction Temperature		T_j	-40 ~ 150	°C
Storage Temperature		T_{stg}	-55 ~ 150	°C
Maximum Junction Temperature		$T_{j(max)}$	150	°C

KIA7805AP~KIA7824AP

EQUIVALENT CIRCUIT

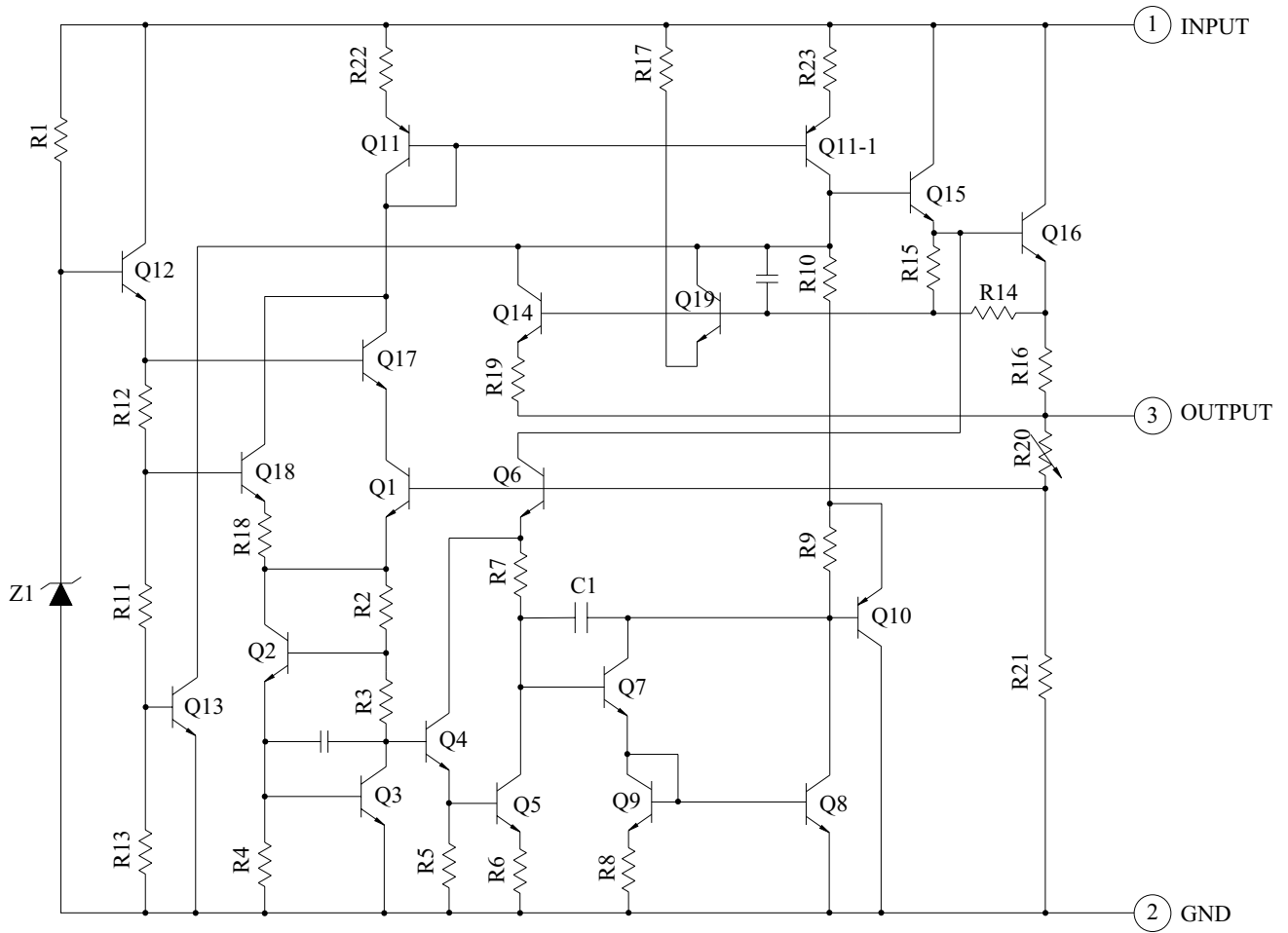

KIA7805AP~KIA7824AP

KIA7805AP

ELECTRICAL CHARACTERISTICS ($V_{IN}=10V$, $I_{OUT}=500mA$, $0^{\circ}C \leq T_j \leq 125^{\circ}C$)

CHARACTERISTIC	SYMBOL	TEST CIRCUIT	TEST CONDITION	MIN.	TYP.	MAX.	UNIT	
Output Voltage	V_{OUT}	Fig. 1	$T_j=25^{\circ}C$, $I_{OUT}=100mA$	4.8	5.0	5.2	V	
Input Regulation	Reg line	Fig. 1	$T_j=25^{\circ}C$	$7.0V \leq V_{IN} \leq 25V$	-	3	100	mV
				$8.0V \leq V_{IN} \leq 12V$	-	1	50	
Load Regulation	Reg load	Fig. 1	$T_j=25^{\circ}C$	$5mA \leq I_{OUT} \leq 1.5A$	-	15	100	mV
				$250mA \leq I_{OUT} \leq 750mA$	-	5	50	
Output Voltage	V_{OUT}	Fig. 1	$7.0V \leq V_{IN} \leq 20V$	4.75	-	5.25	V	
Quiescent Current	I_B	Fig. 1	$T_j=25^{\circ}C$, $I_{OUT}=5mA$	-	4.2	8.0	mA	
Quiescent Current Change	ΔI_B	Fig. 1	$7.0V \leq V_{IN} \leq 25V$	-	-	1.3	mA	
Output Noise Voltage	V_{NO}	Fig. 2	$T_a=25^{\circ}C$, $10Hz \leq f \leq 100kHz$	-	50	-	μV_{rms}	
Ripple Rejection Ratio	RR	Fig. 3	$f=120Hz$, $8.0V \leq V_{IN} \leq 18V$,	62	78	-	dB	
Dropout Voltage	V_D	Fig. 1	$I_{OUT}=1.0A$, $T_j=25^{\circ}C$	-	2.0	-	V	
Short Circuit Current Limit	I_{SC}	Fig. 1	$T_j=25^{\circ}C$	-	1.6	-	A	
Average Temperature Coefficient of Output Voltage	TC_{VO}	Fig. 1	$I_{OUT}=5mA$, $0^{\circ}C \leq T_j \leq 125^{\circ}C$	-	-0.6	-	mV/ $^{\circ}C$	

KIA7805AP~KIA7824AP

KIA7806AP

ELECTRICAL CHARACTERISTICS ($V_{IN}=11V$, $I_{OUT}=500mA$, $0^{\circ}C \leq T_j \leq 125^{\circ}C$)

CHARACTERISTIC	SYMBOL	TEST CIRCUIT	TEST CONDITION	MIN.	TYP.	MAX.	UNIT	
Output Voltage	V_{OUT}	Fig. 1	$T_j=25^{\circ}C$, $I_{OUT}=100mA$	5.75	6.0	6.25	V	
Input Regulation	Reg line	Fig. 1	$T_j=25^{\circ}C$	$8.0V \leq V_{IN} \leq 25V$	-	4	120	mV
				$9V \leq V_{IN} \leq 13V$	-	2	60	
Load Regulation	Reg load	Fig. 1	$T_j=25^{\circ}C$	$5mA \leq I_{OUT} \leq 1.5A$	-	15	120	mV
				$250mA \leq I_{OUT} \leq 750mA$	-	5	60	
Output Voltage	V_{OUT}	Fig. 1	$8V \leq V_{IN} \leq 21V$	5.7	-	6.3	V	
Quiescent Current	I_B	Fig. 1	$T_j=25^{\circ}C$, $I_{OUT}=5mA$	-	4.3	8.0	mA	
Quiescent Current Change	ΔI_B	Fig. 1	$8V \leq V_{IN} \leq 25V$	-	-	1.3	mA	
Output Noise Voltage	V_{NO}	Fig. 2	$T_a=25^{\circ}C$, $10Hz \leq f \leq 100kHz$	-	55	-	μV_{rms}	
Ripple Rejection Ratio	RR	Fig. 3	$f=120Hz$, $9V \leq V_{IN} \leq 19V$,	61	77	-	dB	
Dropout Voltage	V_D	Fig. 1	$I_{OUT}=1.0A$, $T_j=25^{\circ}C$	-	2.0	-	V	
Short Circuit Current Limit	I_{SC}	Fig. 1	$T_j=25^{\circ}C$	-	1.5	-	A	
Average Temperature Coefficient of Output Voltage	TC_{VO}	Fig. 1	$I_{OUT}=5mA$, $0^{\circ}C \leq T_j \leq 125^{\circ}C$	-	-0.7	-	mV/ $^{\circ}C$	

KIA7805AP~KIA7824AP

KIA7807AP

ELECTRICAL CHARACTERISTICS ($V_{IN}=12V$, $I_{OUT}=500mA$, $0^{\circ}C \leq T_j \leq 125^{\circ}C$)

CHARACTERISTIC	SYMBOL	TEST CIRCUIT	TEST CONDITION	MIN.	TYP.	MAX.	UNIT	
Output Voltage	V_{OUT}	Fig. 1	$T_j=25^{\circ}C$, $I_{OUT}=100mA$	6.72	7.0	7.28	V	
Input Regulation	Reg line	Fig. 1	$T_j=25^{\circ}C$	$9V \leq V_{IN} \leq 25V$	-	5	140	mV
				$10V \leq V_{IN} \leq 14V$	-	2	70	
Load Regulation	Reg load	Fig. 1	$T_j=25^{\circ}C$	$5mA \leq I_{OUT} \leq 1.5A$	-	15	140	mV
				$250mA \leq I_{OUT} \leq 750mA$	-	5	70	
Output Voltage	V_{OUT}	Fig. 1	$9V \leq V_{IN} \leq 22V$	6.65	-	7.35	V	
Quiescent Current	I_B	Fig. 1	$T_j=25^{\circ}C$, $I_{OUT}=5mA$	-	4.3	8.0	mA	
Quiescent Current Change	ΔI_B	Fig. 1	$9V \leq V_{IN} \leq 25V$	-	-	1.3	mA	
Output Noise Voltage	V_{NO}	Fig. 2	$T_a=25^{\circ}C$, $10Hz \leq f \leq 100kHz$	-	60	-	μV_{rms}	
Ripple Rejection Ratio	RR	Fig. 3	$f=120Hz$, $10V \leq V_{IN} \leq 20V$,	59	75	-	dB	
Dropout Voltage	V_D	Fig. 1	$I_{OUT}=1.0A$, $T_j=25^{\circ}C$	-	2.0	-	V	
Short Circuit Current Limit	I_{SC}	Fig. 1	$T_j=25^{\circ}C$	-	1.3	-	A	
Average Temperature Coefficient of Output Voltage	TC_{VO}	Fig. 1	$I_{OUT}=5mA$, $0^{\circ}C \leq T_j \leq 125^{\circ}C$	-	-0.8	-	mV/ $^{\circ}C$	

KIA7805AP~KIA7824AP

KIA7808AP

ELECTRICAL CHARACTERISTICS ($V_{IN}=14V$, $I_{OUT}=500mA$, $0\text{ }^{\circ}C \leq T_j \leq 125\text{ }^{\circ}C$)

CHARACTERISTIC	SYMBOL	TEST CIRCUIT	TEST CONDITION	MIN.	TYP.	MAX.	UNIT	
Output Voltage	V_{OUT}	Fig. 1	$T_j=25\text{ }^{\circ}C$, $I_{OUT}=100mA$	7.7	8.0	8.3	V	
Input Regulation	Reg line	Fig. 1	$T_j=25\text{ }^{\circ}C$	$10.5V \leq V_{IN} \leq 25V$	-	6	160	mV
				$11V \leq V_{IN} \leq 17V$	-	2	80	
Load Regulation	Reg load	Fig. 1	$T_j=25\text{ }^{\circ}C$	$5mA \leq I_{OUT} \leq 1.5A$	-	12	160	mV
				$250mA \leq I_{OUT} \leq 750mA$	-	4	80	
Output Voltage	V_{OUT}	Fig. 1	$10.5V \leq V_{IN} \leq 23V$	7.6	-	8.4	V	
Quiescent Current	I_B	Fig. 1	$T_j=25\text{ }^{\circ}C$, $I_{OUT}=5mA$	-	4.3	8.0	mA	
Quiescent Current Change	ΔI_B	Fig. 1	$10.5V \leq V_{IN} \leq 25V$	-	-	1.0	mA	
Output Noise Voltage	V_{NO}	Fig. 2	$T_a=25\text{ }^{\circ}C$, $10Hz \leq f \leq 100kHz$	-	70	-	μV_{rms}	
Ripple Rejection Ratio	RR	Fig. 3	$f=120Hz$, $11.5V \leq V_{IN} \leq 21.5V$,	58	74	-	dB	
Dropout Voltage	V_D	Fig. 1	$I_{OUT}=1.0A$, $T_j=25\text{ }^{\circ}C$	-	2.0	-	V	
Short Circuit Current Limit	I_{SC}	Fig. 1	$T_j=25\text{ }^{\circ}C$	-	1.1	-	A	
Average Temperature Coefficient of Output Voltage	TC_{VO}	Fig. 1	$I_{OUT}=5mA$, $0\text{ }^{\circ}C \leq T_j \leq 125\text{ }^{\circ}C$	-	-1.0	-	mV/ $^{\circ}C$	

KIA7805AP~KIA7824AP

KIA7809AP

ELECTRICAL CHARACTERISTICS ($V_{IN}=15V$, $I_{OUT}=500mA$, $0^{\circ}C \leq T_j \leq 125^{\circ}C$)

CHARACTERISTIC	SYMBOL	TEST CIRCUIT	TEST CONDITION	MIN.	TYP.	MAX.	UNIT	
Output Voltage	V_{OUT}	Fig. 1	$T_j=25^{\circ}C$, $I_{OUT}=100mA$	8.64	9.0	9.36	V	
Input Regulation	Reg line	Fig. 1	$T_j=25^{\circ}C$	$11.5V \leq V_{IN} \leq 26V$	-	7.0	180	mV
				$13V \leq V_{IN} \leq 19V$	-	2.5	90	
Load Regulation	Reg load	Fig. 1	$T_j=25^{\circ}C$	$5mA \leq I_{OUT} \leq 1.5A$	-	12	180	mV
				$250mA \leq I_{OUT} \leq 750mA$	-	4.0	90	
Output Voltage	V_{OUT}	Fig. 1	$11.5V \leq V_{IN} \leq 26V$	8.55	-	9.45	V	
Quiescent Current	I_B	Fig. 1	$T_j=25^{\circ}C$, $I_{OUT}=5mA$	-	4.3	8.0	mA	
Quiescent Current Change	ΔI_B	Fig. 1	$11.5V \leq V_{IN} \leq 26V$	-	-	1.0	mA	
Output Noise Voltage	V_{NO}	Fig. 2	$T_a=25^{\circ}C$, $10Hz \leq f \leq 100kHz$	-	75	-	μV_{rms}	
Ripple Rejection Ratio	RR	Fig. 3	$f=120Hz$, $12.5V \leq V_{IN} \leq 22.5V$,	56	72	-	dB	
Dropout Voltage	V_D	Fig. 1	$I_{OUT}=1.0A$, $T_j=25^{\circ}C$	-	2.0	-	V	
Short Circuit Current Limit	I_{SC}	Fig. 1	$T_j=25^{\circ}C$	-	1.0	-	A	
Average Temperature Coefficient of Output Voltage	TC_{VO}	Fig. 1	$I_{OUT}=5mA$, $0^{\circ}C \leq T_j \leq 125^{\circ}C$	-	-1.1	-	mV/ $^{\circ}C$	

KIA7805AP~KIA7824AP

KIA7810AP

ELECTRICAL CHARACTERISTICS ($V_{IN}=16V$, $I_{OUT}=500mA$, $0\text{ }^{\circ}C \leq T_j \leq 125\text{ }^{\circ}C$)

CHARACTERISTIC	SYMBOL	TEST CIRCUIT	TEST CONDITION	MIN.	TYP.	MAX.	UNIT	
Output Voltage	V_{OUT}	Fig. 1	$T_j=25\text{ }^{\circ}C$, $I_{OUT}=100mA$	9.6	10.0	10.4	V	
Input Regulation	Reg line	Fig. 1	$T_j=25\text{ }^{\circ}C$	$12.5V \leq V_{IN} \leq 27V$	-	8	200	mV
				$14V \leq V_{IN} \leq 20V$	-	2.5	100	
Load Regulation	Reg load	Fig. 1	$T_j=25\text{ }^{\circ}C$	$5mA \leq I_{OUT} \leq 1.5A$	-	12	200	mV
				$250mA \leq I_{OUT} \leq 750mA$	-	4	100	
Output Voltage	V_{OUT}	Fig. 1	$12.5V \leq V_{IN} \leq 25V$	9.5	-	10.5	V	
Quiescent Current	I_B	Fig. 1	$T_j=25\text{ }^{\circ}C$, $I_{OUT}=5mA$	-	4.3	8.0	mA	
Quiescent Current Change	ΔI_B	Fig. 1	$12.5V \leq V_{IN} \leq 27V$	-	-	1.0	mA	
Output Noise Voltage	V_{NO}	Fig. 2	$T_a=25\text{ }^{\circ}C$, $10Hz \leq f \leq 100kHz$	-	80	-	μV_{rms}	
Ripple Rejection Ratio	RR	Fig. 3	$f=120Hz$, $13.5V \leq V_{IN} \leq 23.5V$,	55	72	-	dB	
Dropout Voltage	V_D	Fig. 1	$I_{OUT}=1.0A$, $T_j=25\text{ }^{\circ}C$	-	2.0	-	V	
Short Circuit Current Limit	I_{SC}	Fig. 1	$T_j=25\text{ }^{\circ}C$	-	0.9	-	A	
Average Temperature Coefficient of Output Voltage	TC_{VO}	Fig. 1	$I_{OUT}=5mA$, $0\text{ }^{\circ}C \leq T_j \leq 125\text{ }^{\circ}C$	-	-1.3	-	mV/ $^{\circ}C$	

KIA7805AP~KIA7824AP

KIA7812AP

ELECTRICAL CHARACTERISTICS ($V_{IN}=19V$, $I_{OUT}=500mA$, $0^{\circ}C \leq T_j \leq 125^{\circ}C$)

CHARACTERISTIC	SYMBOL	TEST CIRCUIT	TEST CONDITION	MIN.	TYP.	MAX.	UNIT	
Output Voltage	V_{OUT}	Fig. 1	$T_j=25^{\circ}C$, $I_{OUT}=100mA$	11.5	12.0	12.5	V	
Input Regulation	Reg line	Fig. 1	$T_j=25^{\circ}C$	$14.5V \leq V_{IN} \leq 30V$	-	10	240	mV
				$16V \leq V_{IN} \leq 22V$	-	3	120	
Load Regulation	Reg load	Fig. 1	$T_j=25^{\circ}C$	$5mA \leq I_{OUT} \leq 1.5A$	-	12	240	mV
				$250mA \leq I_{OUT} \leq 750mA$	-	4	120	
Output Voltage	V_{OUT}	Fig. 1	$14.5V \leq V_{IN} \leq 27V$	11.4	-	12.6	V	
Quiescent Current	I_B	Fig. 1	$T_j=25^{\circ}C$, $I_{OUT}=5mA$	-	4.3	8.0	mA	
Quiescent Current Change	ΔI_B	Fig. 1	$14.5V \leq V_{IN} \leq 30V$	-	-	1.0	mA	
Output Noise Voltage	V_{NO}	Fig. 2	$T_a=25^{\circ}C$, $10Hz \leq f \leq 100kHz$	-	90	-	μV_{rms}	
Ripple Rejection Ratio	RR	Fig. 3	$f=120Hz$, $15V \leq V_{IN} \leq 25V$,	55	71	-	dB	
Dropout Voltage	V_D	Fig. 1	$I_{OUT}=1.0A$, $T_j=25^{\circ}C$	-	2.0	-	V	
Short Circuit Current Limit	I_{SC}	Fig. 1	$T_j=25^{\circ}C$	-	0.7	-	A	
Average Temperature Coefficient of Output Voltage	TC_{VO}	Fig. 1	$I_{OUT}=5mA$, $0^{\circ}C \leq T_j \leq 125^{\circ}C$	-	-1.6	-	mV/ $^{\circ}C$	

KIA7805AP~KIA7824AP

KIA7815AP

ELECTRICAL CHARACTERISTICS ($V_{IN}=23V$, $I_{OUT}=500mA$, $0^{\circ}C \leq T_j \leq 125^{\circ}C$)

CHARACTERISTIC	SYMBOL	TEST CIRCUIT	TEST CONDITION	MIN.	TYP.	MAX.	UNIT	
Output Voltage	V_{OUT}	Fig. 1	$T_j=25^{\circ}C$, $I_{OUT}=100mA$	14.4	15.0	15.6	V	
Input Regulation	Reg line	Fig. 1	$T_j=25^{\circ}C$	$17.5V \leq V_{IN} \leq 30V$	-	11	300	mV
				$20V \leq V_{IN} \leq 26V$	-	3	150	
Load Regulation	Reg load	Fig. 1	$T_j=25^{\circ}C$	$5mA \leq I_{OUT} \leq 1.5A$	-	12	300	mV
				$250mA \leq I_{OUT} \leq 750mA$	-	4	150	
Output Voltage	V_{OUT}	Fig. 1	$17.5V \leq V_{IN} \leq 30V$	14.25	-	15.75	V	
Quiescent Current	I_B	Fig. 1	$T_j=25^{\circ}C$, $I_{OUT}=5mA$	-	4.4	8.0	mA	
Quiescent Current Change	ΔI_B	Fig. 1	$17.5V \leq V_{IN} \leq 30V$	-	-	1.0	mA	
Output Noise Voltage	V_{NO}	Fig. 2	$T_a=25^{\circ}C$, $10Hz \leq f \leq 100kHz$	-	110	-	μV_{rms}	
Ripple Rejection Ratio	RR	Fig. 3	$f=120Hz$, $18.5V \leq V_{IN} \leq 28.5V$,	54	70	-	dB	
Dropout Voltage	V_D	Fig. 1	$I_{OUT}=1.0A$, $T_j=25^{\circ}C$	-	2.0	-	V	
Short Circuit Current Limit	I_{SC}	Fig. 1	$T_j=25^{\circ}C$	-	0.5	-	A	
Average Temperature Coefficient of Output Voltage	TC_{VO}	Fig. 1	$I_{OUT}=5mA$, $0^{\circ}C \leq T_j \leq 125^{\circ}C$	-	-2.0	-	mV/ $^{\circ}C$	

KIA7805AP~KIA7824AP

KIA7818AP

ELECTRICAL CHARACTERISTICS ($V_{IN}=27V$, $I_{OUT}=500mA$, $0^{\circ}C \leq T_j \leq 125^{\circ}C$)

CHARACTERISTIC	SYMBOL	TEST CIRCUIT	TEST CONDITION	MIN.	TYP.	MAX.	UNIT	
Output Voltage	V_{OUT}	Fig. 1	$T_j=25^{\circ}C$, $I_{OUT}=100mA$	17.3	18.0	18.7	V	
Input Regulation	Reg line	Fig. 1	$T_j=25^{\circ}C$	$21V \leq V_{IN} \leq 33V$	-	13	360	mV
				$24V \leq V_{IN} \leq 30V$	-	4	180	
Load Regulation	Reg load	Fig. 1	$T_j=25^{\circ}C$	$5mA \leq I_{OUT} \leq 1.5A$	-	12	360	mV
				$250mA \leq I_{OUT} \leq 750mA$	-	4	180	
Output Voltage	V_{OUT}	Fig. 1	$21V \leq V_{IN} \leq 33V$	17.1	-	18.9	V	
Quiescent Current	I_B	Fig. 1	$T_j=25^{\circ}C$, $I_{OUT}=5mA$	-	4.5	8.0	mA	
Quiescent Current Change	ΔI_B	Fig. 1	$21V \leq V_{IN} \leq 33V$	-	-	1.0	mA	
Output Noise Voltage	V_{NO}	Fig. 2	$T_a=25^{\circ}C$, $10Hz \leq f \leq 100kHz$	-	125	-	μV_{rms}	
Ripple Rejection Ratio	RR	Fig. 3	$f=120Hz$, $22V \leq V_{IN} \leq 32V$,	52	68	-	dB	
Dropout Voltage	V_D	Fig. 1	$I_{OUT}=1.0A$, $T_j=25^{\circ}C$	-	2.0	-	V	
Short Circuit Current Limit	I_{SC}	Fig. 1	$T_j=25^{\circ}C$	-	0.4	-	A	
Average Temperature Coefficient of Output Voltage	TC_{VO}	Fig. 1	$I_{OUT}=5mA$, $0^{\circ}C \leq T_j \leq 125^{\circ}C$	-	-2.5	-	mV/ $^{\circ}C$	

KIA7805AP~KIA7824AP

KIA7820AP

ELECTRICAL CHARACTERISTICS ($V_{IN}=29V$, $I_{OUT}=500mA$, $0^{\circ}C \leq T_j \leq 125^{\circ}C$)

CHARACTERISTIC	SYMBOL	TEST CIRCUIT	TEST CONDITION	MIN.	TYP.	MAX.	UNIT	
Output Voltage	V_{OUT}	Fig. 1	$T_j=25^{\circ}C$, $I_{OUT}=100mA$	19.2	20.0	20.8	V	
Input Regulation	Reg line	Fig. 1	$T_j=25^{\circ}C$	$23V \leq V_{IN} \leq 35V$	-	15	400	mV
				$26V \leq V_{IN} \leq 32V$	-	5	200	
Load Regulation	Reg load	Fig. 1	$T_j=25^{\circ}C$	$5mA \leq I_{OUT} \leq 1.5A$	-	12	400	mV
				$250mA \leq I_{OUT} \leq 750mA$	-	4	200	
Output Voltage	V_{OUT}	Fig. 1	$23V \leq V_{IN} \leq 35V$	19.0	-	21.0	V	
Quiescent Current	I_B	Fig. 1	$T_j=25^{\circ}C$, $I_{OUT}=5mA$	-	4.6	8.0	mA	
Quiescent Current Change	ΔI_B	Fig. 1	$23V \leq V_{IN} \leq 35V$	-	-	1.0	mA	
Output Noise Voltage	V_{NO}	Fig. 2	$T_a=25^{\circ}C$, $10Hz \leq f \leq 100kHz$	-	135	-	μV_{rms}	
Ripple Rejection Ratio	RR	Fig. 3	$f=120Hz$, $24V \leq V_{IN} \leq 34V$,	50	66	-	dB	
Dropout Voltage	V_D	Fig. 1	$I_{OUT}=1.0A$, $T_j=25^{\circ}C$	-	2.0	-	V	
Short Circuit Current Limit	I_{SC}	Fig. 1	$T_j=25^{\circ}C$	-	0.4	-	A	
Average Temperature Coefficient of Output Voltage	TC_{VO}	Fig. 1	$I_{OUT}=5mA$, $0^{\circ}C \leq T_j \leq 125^{\circ}C$	-	-3.0	-	mV/ $^{\circ}C$	

KIA7805AP~KIA7824AP

KIA7824AP

ELECTRICAL CHARACTERISTICS ($V_{IN}=33V$, $I_{OUT}=500mA$, $0^{\circ}C \leq T_j \leq 125^{\circ}C$)

CHARACTERISTIC	SYMBOL	TEST CIRCUIT	TEST CONDITION	MIN.	TYP.	MAX.	UNIT	
Output Voltage	V_{OUT}	Fig. 1	$T_j=25^{\circ}C$, $I_{OUT}=100mA$	23.0	24.0	25.0	V	
Input Regulation	Reg line	Fig. 1	$T_j=25^{\circ}C$	$27V \leq V_{IN} \leq 38V$	-	18	480	mV
				$30V \leq V_{IN} \leq 36V$	-	6	240	
Load Regulation	Reg load	Fig. 1	$T_j=25^{\circ}C$	$5mA \leq I_{OUT} \leq 1.5A$	-	12	480	mV
				$250mA \leq I_{OUT} \leq 750mA$	-	4	240	
Output Voltage	V_{OUT}	Fig. 1	$27V \leq V_{IN} \leq 38V$	22.8	-	25.2	V	
Quiescent Current	I_B	Fig. 1	$T_j=25^{\circ}C$, $I_{OUT}=5mA$	-	4.6	8.0	mA	
Quiescent Current Change	ΔI_B	Fig. 1	$27V \leq V_{IN} \leq 38V$	-	-	1.0	mA	
Output Noise Voltage	V_{NO}	Fig. 2	$T_a=25^{\circ}C$, $10Hz \leq f \leq 100kHz$	-	150	-	μV_{rms}	
Ripple Rejection Ratio	RR	Fig. 3	$f=120Hz$, $28V \leq V_{IN} \leq 38V$,	50	66	-	dB	
Dropout Voltage	V_D	Fig. 1	$I_{OUT}=1.0A$, $T_j=25^{\circ}C$	-	2.0	-	V	
Short Circuit Current Limit	I_{SC}	Fig. 1	$T_j=25^{\circ}C$	-	0.3	-	A	
Average Temperature Coefficient of Output Voltage	TC_{VO}	Fig. 1	$I_{OUT}=5mA$, $0^{\circ}C \leq T_j \leq 125^{\circ}C$	-	-3.5	-	mV/ $^{\circ}C$	

KIA7805AP~KIA7824AP

TEST CIRCUIT

Fig. 1 Standard Test Circuit & Application Circuit

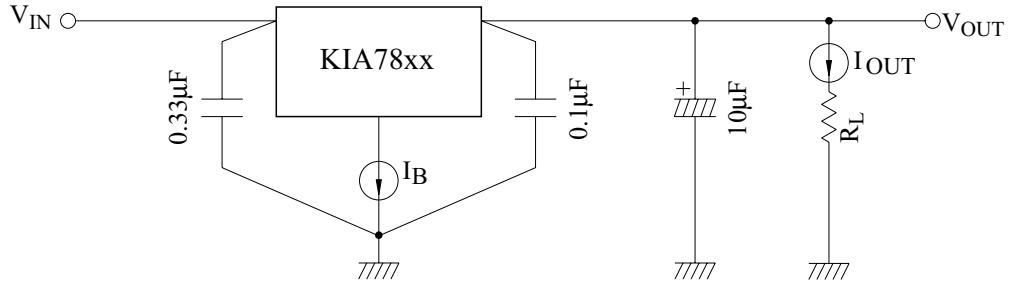

Fig. 2 V_{NO} Test Circuit

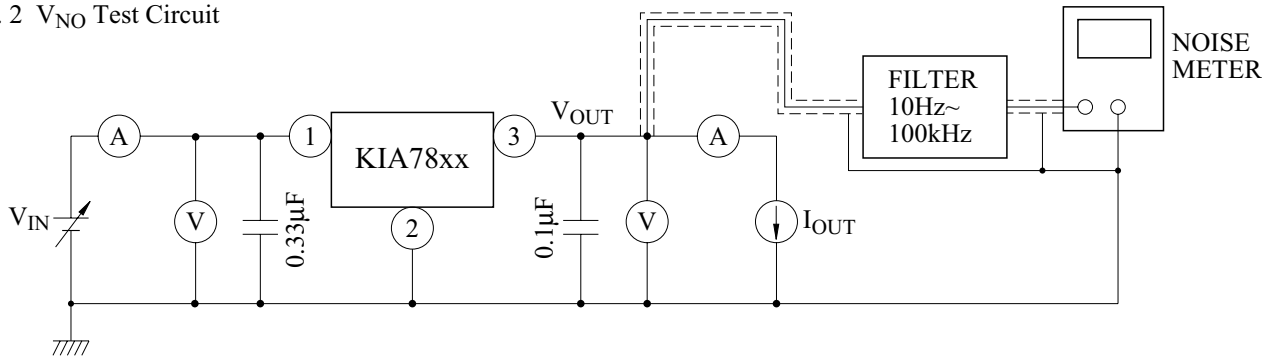
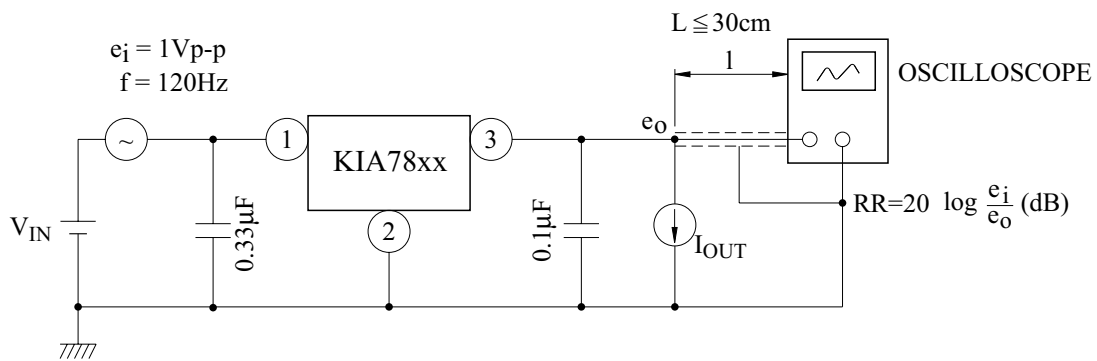

Fig. 3 Ripple Rejection Test Circuit



KIA7805AP~KIA7824AP

APPLICATION CIRCUIT

(1) VOLTAGE BOOST REGULATOR

(a) Voltage boost by use of zener diode

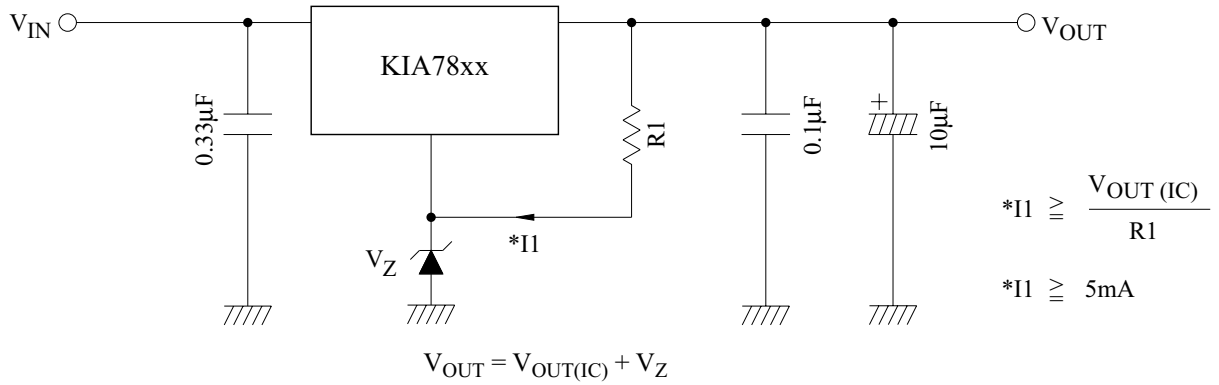

(b) Voltage boost by use of resistor

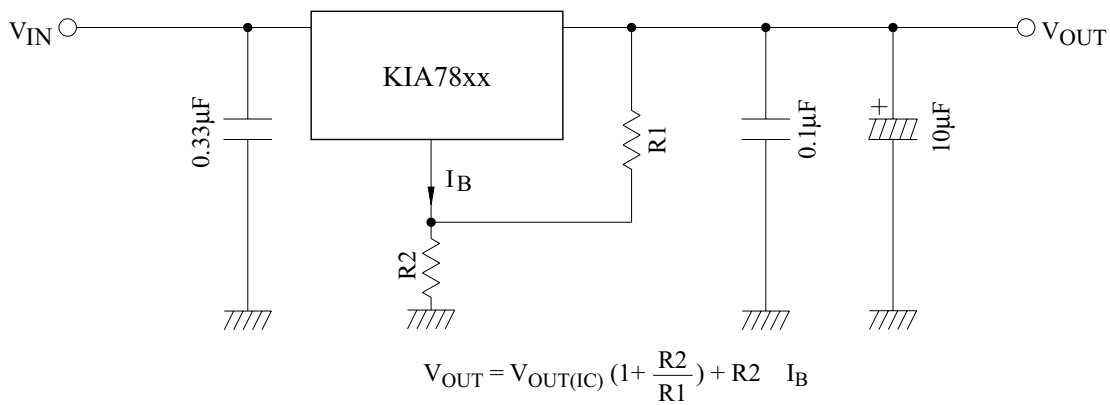

(c) Adjustable output regulator

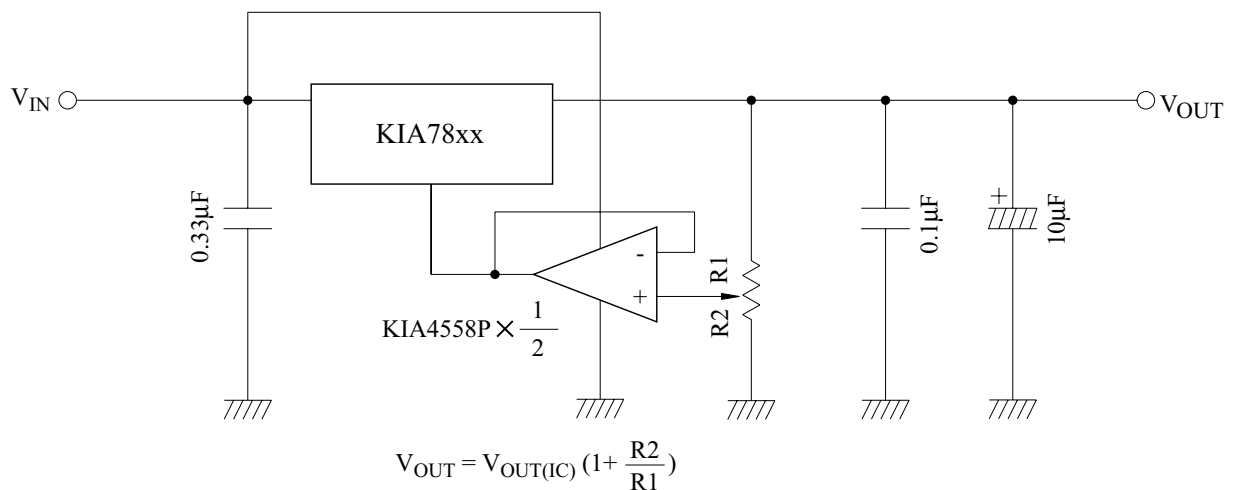

KIA7805AP~KIA7824AP

(2) CURRENT BOOST REGULATOR

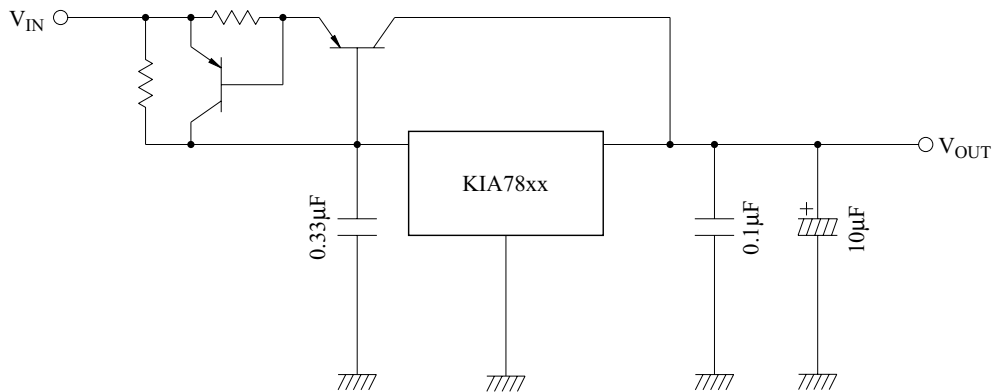

PRECAUTIONS ON APPLICATION

- (1) In regard to GND, be careful not to apply a negative voltage to the input/output terminal. Further, special care is necessary in case of a voltage boost application.
- (2) When a surge voltage exceeding maximum rating is applied to the input terminal or when a voltage in excess of the input terminal voltage is applied to the output terminal, the circuit may be destroyed. Specially, in the latter case, great care is necessary. Further, if the input terminal shorts to GND in a state of normal operation, the output terminal voltage becomes higher than the input voltage (GND potential), and the electric charge of a chemical capacitor connected to the output terminal flows into the input side, which may cause the destruction of circuit. In these cases, take such steps as a zener diode and a general silicon diode are connected to the circuit, as shown in the following figure.

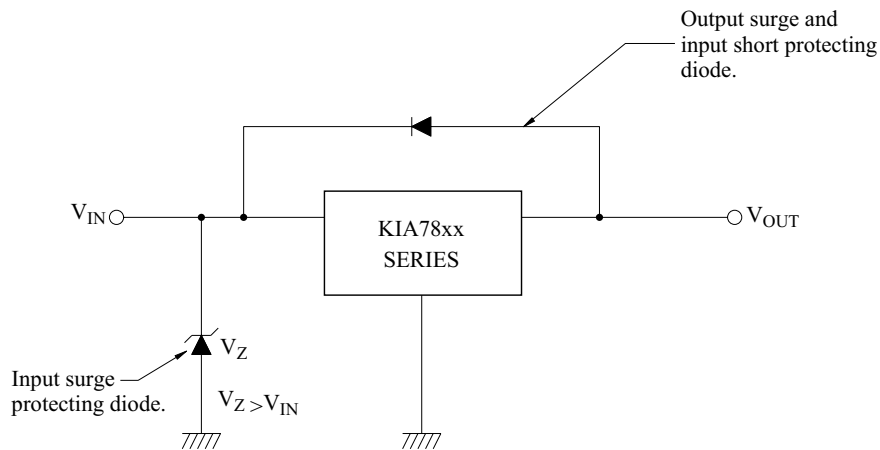

- (3) When the input voltage is too high, the power dissipation of three terminal regulator increase because of series regulator, so that the junction temperature rises. In such a case, it is recommended to reduce the power dissipation by inserting the power limiting resistor R_{SD} in the input terminal, and to reduce the junction temperature as a result.

KIA7805AP~KIA7824AP

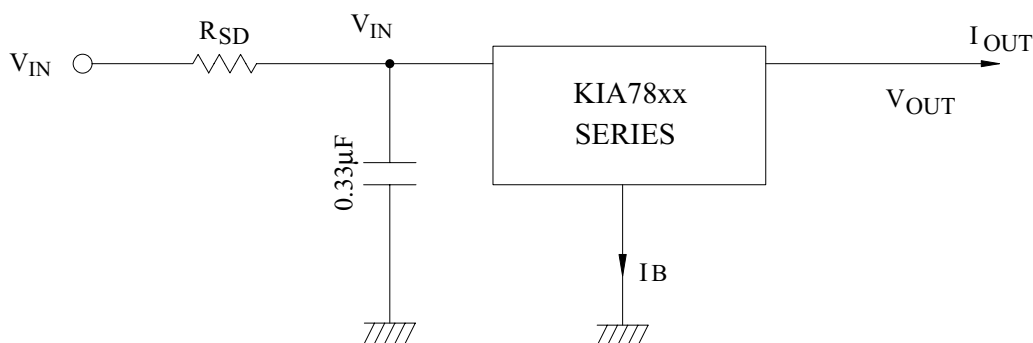

The power dissipation P_D of IC is expressed in the following equation.

$$P_D = (V_{IN}' - V_{OUT}) \cdot I_{OUT} + V_{IN}' \cdot I_B$$

If V_{IN}' is reduced below the lowest voltage necessary for the IC, the parasitic oscillation will be caused according to circumstances. In determining the resistance value of R_{SD} , design with margin should be made by making reference to the following equation.

$$R_{SD} < \frac{V_{IN} - V_{IN}'}{I_{OUT} + I_B}$$

(4) Connect the input terminal and GND, and the output terminal and GND, by capacitor respectively.

The capacitances should be determined experimentally because they depend on printed patterns. In particular, adequate investigation should be made so that there is no problem even at time of high or low temperature.

(5) Installation of IC for power supply

For obtaining high reliability on the heat sink design of the regulator IC, it is generally required to derate more than 20% of maximum junction temperature (T_j MAX.) Further, full consideration should be given to the installation of IC to the heat sink.

(a) Heat sink design

The thermal resistance of IC itself is required from the viewpoint of the design of elements, but the thermal resistance from the IC package to the open air varies with the contact thermal resistance. Table 1 shows how much the value of the contact thermal resistance ($\theta_C + \theta_S$) is changed by insulating sheet (mica) and heat sink grease.

TABLE 1.

UNIT: °C/W

PACKAGE	MODEL NO.	TORQUE	MICA	$\theta_C + \theta_S$
TO-220AB	KIA78xxAP	6kg · cm (0.6N/m)	Not Provided	0.3 ~ 0.5(1.5 ~ 2.0)
			Provided	2.0 ~ 2.5(4.0 ~ 6.0)

The figures given in parentheses denote the values at time of no grease.

The package of regulator IC serves as GND, therefore, usually use the value at time of "no mica"

(b) Silicon grease

When a circuit not exceeding maximum rating is designed, it is to be desired that the grease should be used if possible. If it is required that the contact thermal resistance is reduced from the view-point of the circuit design, It is recommended that the following methods be adopted.

A: Use Thercon (Fuji High Polymer Kogyo K.K)

B: Use SC101 (Torei Silicon) or G-640 (GE), if grease is used.

(c) Torque

When installing IC on a heat sink or the like, tighten the IC with the torque of less than the rated value. If it is tightened with the torque in excess of the rated value, sometimes the internal elements of the IC are adversely affected. Therefore, great care should be given to the installing operation. Further, if polycarbonate screws are used, the torque causes a change with the passage of time, which may lessen the effect of radiation.

KIA7805AP~KIA7824AP

(6) IEC (International Electrotechnical Commission)-65 Specification.

(a) IEC (International Electrotechnical Commission)-65 is the standard, parts testing method, machinery and tools (used in connecting main power directly and indirectly) Which are used at home and general building. The purpose of the above standard is not to breaking out the risk which is related to an electric shock, a heating, a fire and the damage of surrounding parts in the case of normal or abnormal operating.

(b) In case temperature is limited by temperature overheating prevention device, fuse or the operation of fuse resistor

One must calculate the temperature of PCB substrate in 2 minute.

$$\Delta T \leq 110 \text{ }^{\circ}\text{C regulated}$$

$$\Delta T = T(\text{The PCB substrate temperature in 2 minute})$$

$$-T_a(\text{Ambient temperature})$$

(c) Graph

As the territory of the deviant line appear by the heat, as the area is wider, T(The PCB substrate temperature in 2 minute) is becoming high.

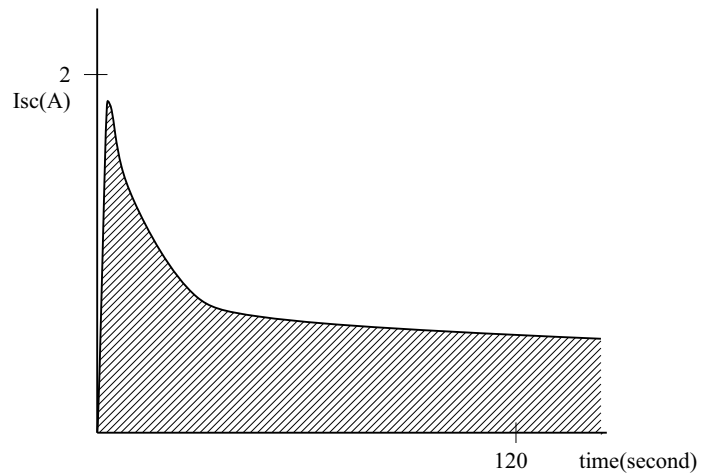

KIA7805AP~KIA7824AP

Fig. 4 $I_B - T_j$

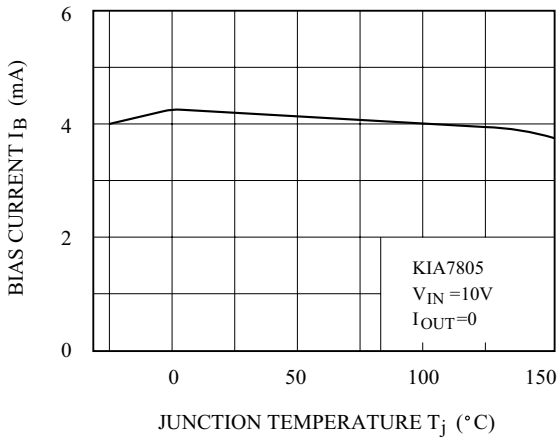

Fig. 5 $V_{OUT} - T_j$

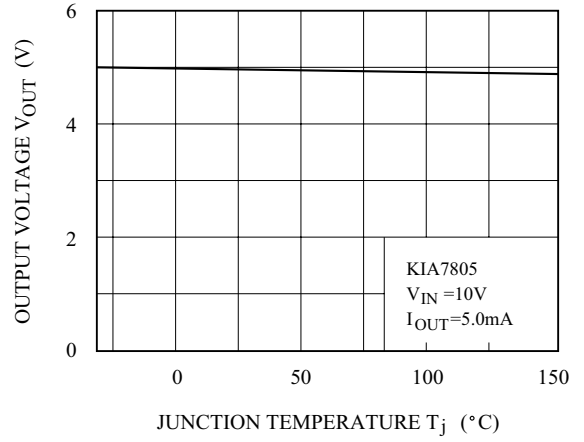

Fig. 6 $RR - I_{OUT}$

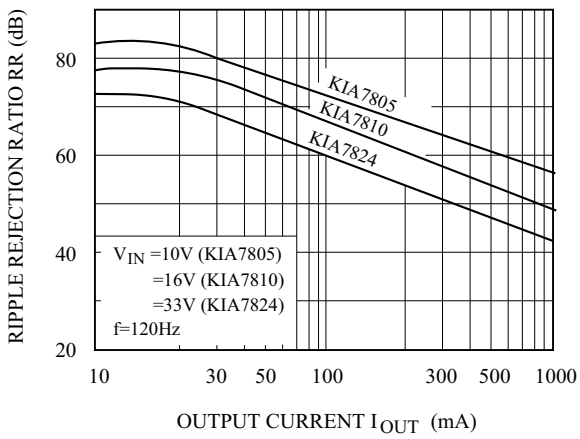
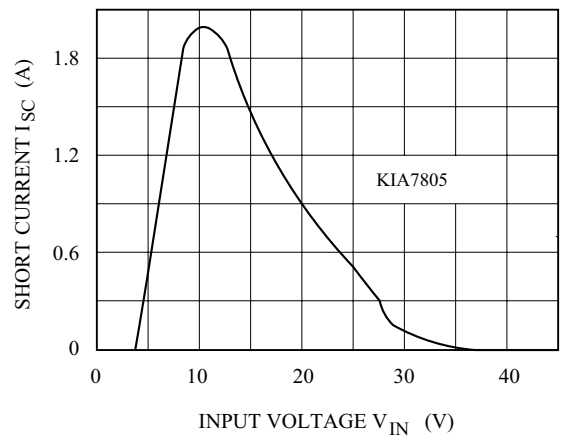

Fig. 7 $V_{IN} - I_{SC}$



KIA7805AP~KIA7824AP

Fig. 8 $V_D - T_j$

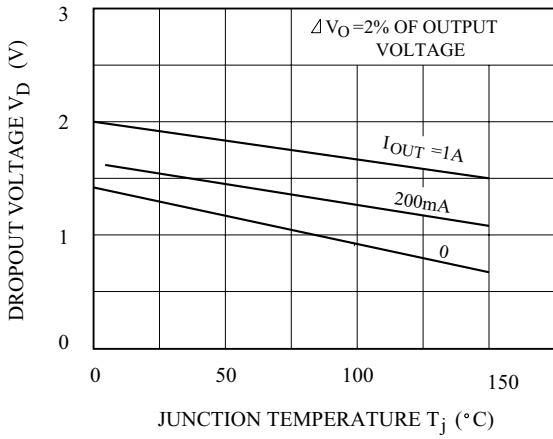

Fig. 9 $Z_{OUT} - f$

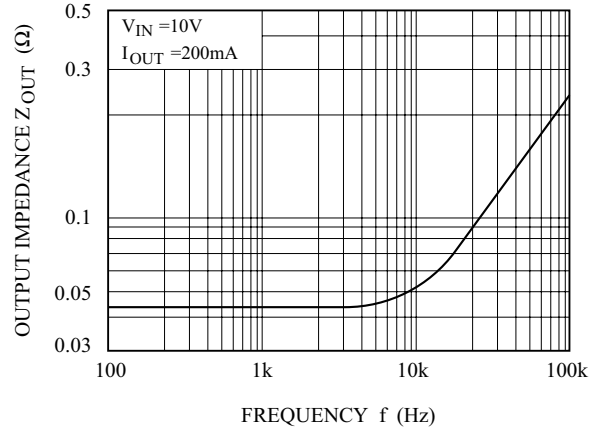

Fig. 10 $P_D - T_a$

