

LM2787

Low Noise Regulated Switched Capacitor Voltage Inverter in micro SMD

General Description

The LM2787 CMOS Negative Regulated Switched Capacitor Voltage Inverter delivers a very low noise adjustable output for an input voltage in the range of +2.7V to +5.5V. Four low cost capacitors are used in this circuit to provide up to 10mA of output current. The regulated output for the LM2787 is adjustable between -1.5V and -5.2V. The LM2787 operates at 260 kHz (typical) switching frequency to reduce output resistance and voltage ripple. With an operating current of only 400 μ A (charge pump power efficiency greater than 90% with most loads) and 0.05 μ A typical shutdown current, the LM2787 provides ideal performance for cellular phone power amplifier bias and other low current, low noise negative voltage needs. The device comes in a small 8-Bump micro SMD package.

Features

- Inverts and regulates the input supply voltage
- Small 8-Bump micro SMD package
- 91% typical charge pump power efficiency at 10mA
- Low output ripple
- Shutdown lowers Quiescent current to 0.05 μ A (typical)

Applications

- Wireless Communication Systems
- Cellular Phone Power Amplifier Biasing
- Interface Power Supplies
- Handheld Instrumentation
- Laptop Computers and PDA's

Typical Application Circuit and Connection Diagram

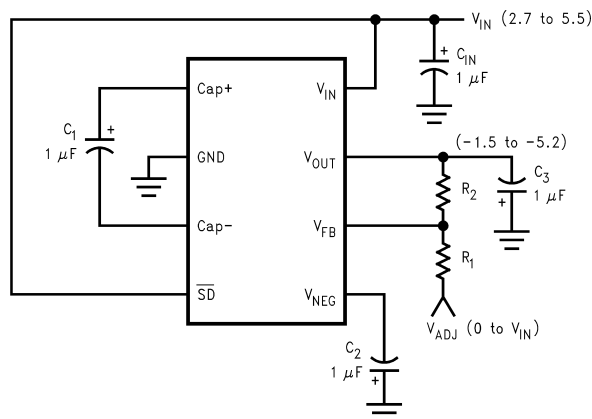

10131325

8-Bump micro SMD (Top View)

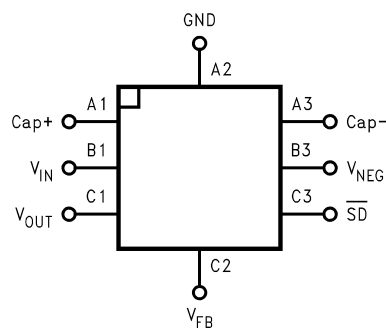

10131302

Ordering Information

Device Order Number	Package Number	Package Marking*	Supplies As
LM2787BP	BPA08CCB	S8	Tape and Reel (250 units/reel)
LM2787BPX	BPA08CCB	S8	Tape and Reel (3000 units/reel)

Note: * The small physical size of the micro SMD package does not allow for the full part number marking. Devices will be marked with the designation shown in the column Package Marking.

Pin Descriptions

Pin No.	Name	Function
A1	Cap+	Positive terminal for C ₁ .
B1	V _{IN}	Positive power supply input.
C1	V _{OUT}	Regulated negative output voltage.
C2	V _{FB}	Feedback input. Connect V _{FB} to an external resistor divider between V _{OUT} and a positive adjust voltage V _{ADJ} ($0 \leq V_{ADJ} \leq V_{IN}$). DO NOT leave unconnected.
C3	SD	Active low, logic-level shutdown input.
B3	V _{NEG}	Negative unregulated output voltage.
A3	Cap-	Negative terminal for C ₁ .
A2	GND	Ground.

Absolute Maximum Ratings (Note 1)

If Military/Aerospace specified devices are required, please contact the National Semiconductor Sales Office/Distributors for availability and specifications.

Supply Voltage (V_{IN} to GND or GND to OUT)	+ 5.8V
\overline{SD}	(GND – 0.3V) to ($V_{IN} + 0.3V$)
V_{NEG} and V_{OUT} Continuous Output Current	10mA
V_{OUT} Short-Circuit Duration to GND (Note 2)	1 sec.
Continuous Power Dissipation ($T_A = 25^\circ\text{C}$) (Note 3)	600mW

T_{JMAX} (Note 3)	150°C
θ_{JA} (Note 3)	220°C/W
Operating Input Voltage Range	2.7V to 5.5V
Operating Output Current Range	0mA to 10mA
Operating Ambient Temp. Range	-40°C to 85°C
Operating Junction Temp. Range	-40°C to 110°C
Storage Temperature	-65°C to 150°C
Lead Temp. (Soldering, 10 sec.)	300°C
ESD Rating (Note 4)	2kV

Electrical Characteristics

Limits with standard typeface apply for $T_J = 25^\circ\text{C}$, and limits in **boldface type** apply over the full temperature range. Unless otherwise specified $V_{IN} = 3.6V$, $C_1 = C_2 = C_3 = 1\mu\text{F}$.

Symbol	Parameter	Conditions	Min	Typ	Max	Units
I_Q	Supply Current	Open Circuit, No Load		400	950	μA
I_{SD}	Shutdown Supply Current			0.05	1	μA
F_{SW}	Switching Frequency (Note 5)	$V_{IN} = 3.6V$	140	260	450	kHz
η_{POWER}	Power Efficiency at V_{NEG}	$I_L = 3.6\text{mA}$ $I_L = 10\text{mA}$		94 91		%
T_{START}	Start Up time			120	600	μs
R_{NEG}	Output Resistance to V_{NEG}	(Note 6)		30		Ω
V_R	Output Voltage Ripple (Note 7)	$I_L = 2.5\text{mA}$, $V_{OUT} = -2.7V$ $I_L = 10\text{mA}$, $V_{OUT} = -3.8V$		1		mV
V_{FB}	Feedback Pin Reference Voltage	$I_L = 2.5\text{mA}$ (Note 8)	-1.25	-1.20	-1.15	V
V_{OUT}	Adjustable Output Voltage	$5.5V \geq V_{IN} \geq 2.7V$, $2.5\text{mA} \geq I_L$ $5.5V \geq V_{IN} \geq 3.0V$, $10\text{mA} \geq I_L \geq 0\text{mA}$	-($V_{IN} - 0.3V$) -($V_{IN} - 1.2V$)			V
	Load Regulation	0 to 10mA, $V_{OUT} = -2.4V$		5		mV/mA
	Line Regulation	$5.5V \geq V_{IN} \geq 2.7V$, $I_L = 2.5\text{mA}$		1		mV/V
V_{IH}	Shutdown Pin Input Voltage High	$5.5V \geq V_{IN} \geq 2.7V$	2.4			V
V_{IL}	Shutdown Pin Input Voltage Low	$5.5V \geq V_{IN} \geq 2.7V$			0.8	V

Note 1: Absolute Maximum Ratings indicate limits beyond which damage to the device may occur. Electrical specifications do not apply when operating the device beyond its rated operating conditions.

Note 2: OUT may be shorted to GND for one second without damage. However, shorting OUT to V_{IN} may damage the device and must be avoided. Also, for temperatures above $T_A = 85^\circ\text{C}$, OUT must not be shorted to GND or V_{IN} or device may be damaged.

Note 3: The maximum power dissipation must be de-rated at elevated temperatures and is limited by T_{JMAX} (maximum junction temperature), T_A (ambient temperature) and θ_{JA} (junction-to-ambient thermal resistance). The maximum power dissipation at any temperature is:

$$PD_{Diss_{MAX}} = (T_{JMAX} - T_A)/\theta_{JA} \text{ up to the value listed in the Absolute Maximum Ratings.}$$

Note 4: Rating is for the human body model, a 100pF capacitor discharged through a 1.5 k Ω resistor into each pin.

Note 5: The output switches operate at one half the oscillator frequency, $f_{OSC} = 2f_{SW}$.

Note 6: Current drawn from V_{NEG} pin decreases power efficiency and will increase output voltage ripple.

Note 7: In the test circuit, capacitors C_1 , C_2 , and C_3 are 1 μF , 0.30 Ω maximum ESR capacitors. Capacitors with higher ESR will increase output resistance, increase output voltage ripple, and reduce efficiency.

Note 8: The feedback resistors R1 and R2 are 200k Ω resistors.

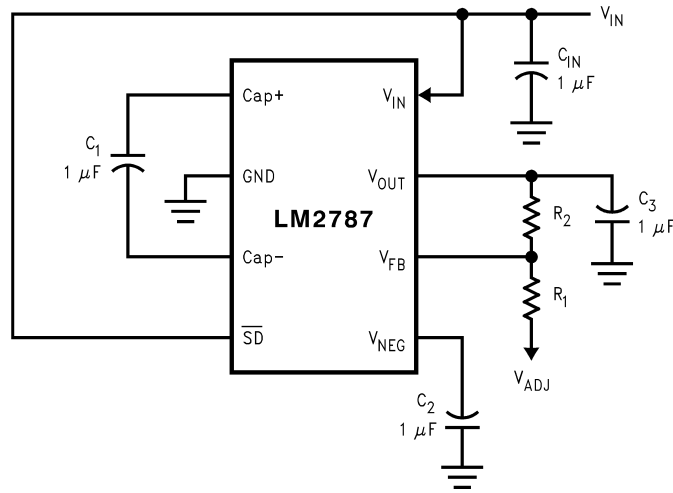

10131326

FIGURE 1. Standard Application Circuit

Typical Performance Characteristics Unless otherwise specified, $T_A = 25^\circ\text{C}$, $V_{OUT} = -2.5\text{V}$.

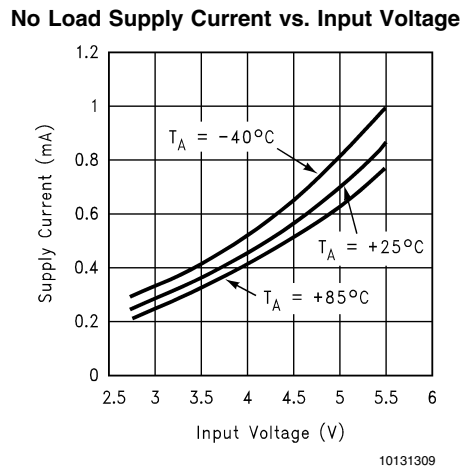
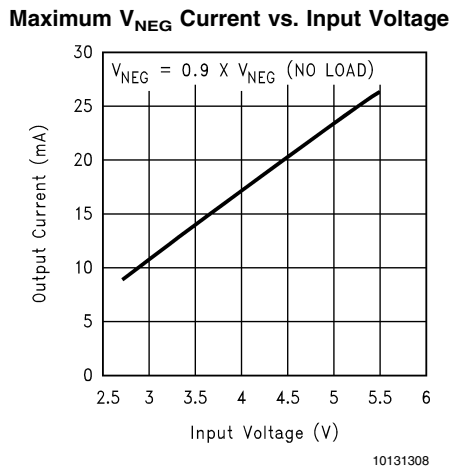
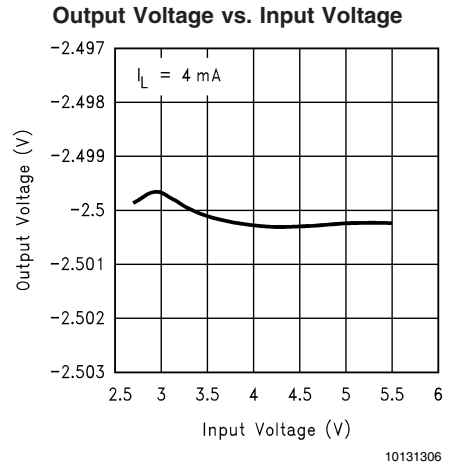
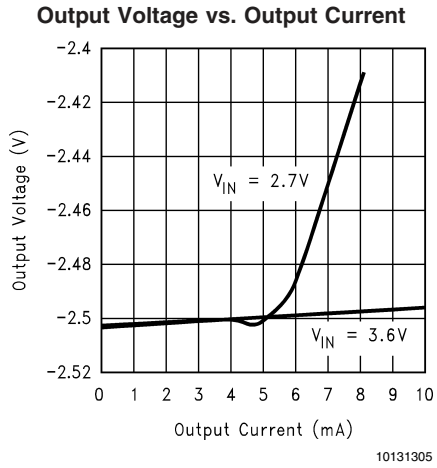

Typical Performance Characteristics Unless otherwise specified, $T_A = 25^\circ\text{C}$, $V_{OUT} = -2.5\text{V}$. (Continued)

Switching Frequency vs. Input Voltage

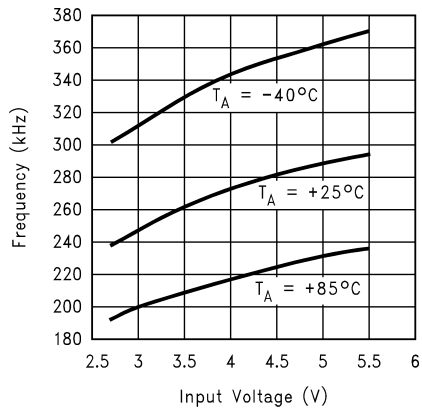

10131311

V_{FB} vs. Temperature

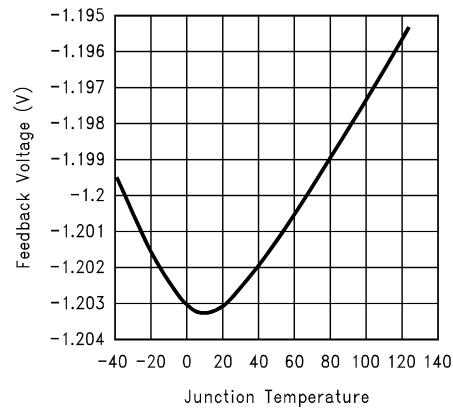

10131315

Start-up Time vs. Input Voltage

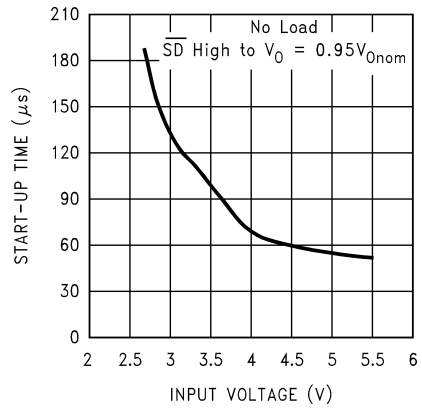

10131310

Start-up from Shutdown (no load)

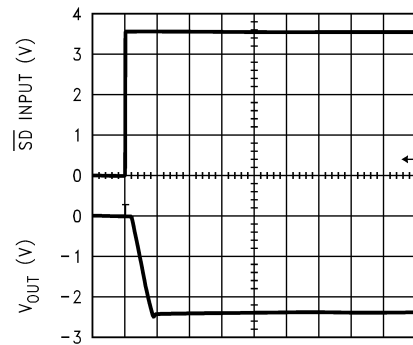

10131312

Output Ripple

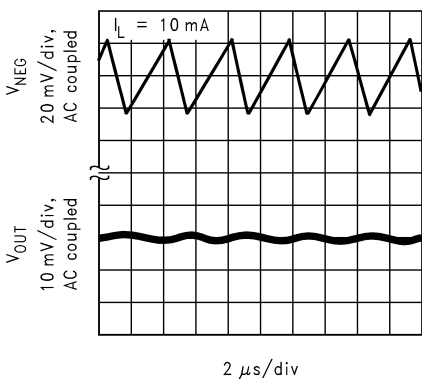

10131313

Output Noise Spectrum

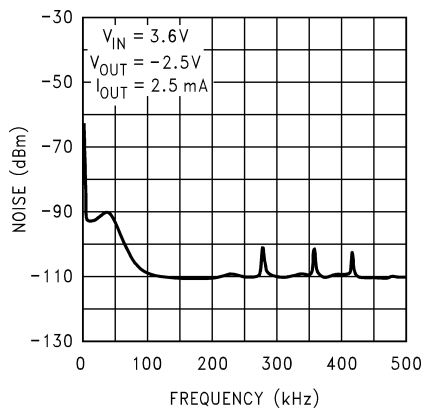

10131324

Typical Performance Characteristics Unless otherwise specified, $T_A = 25^\circ\text{C}$, $V_{OUT} = -2.5\text{V}$. (Continued)

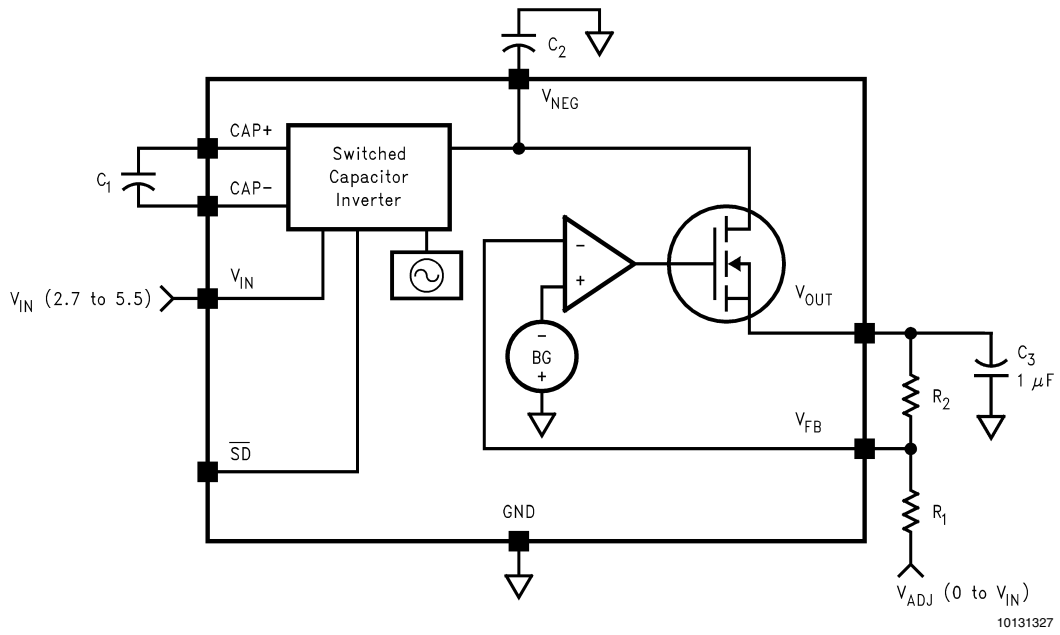
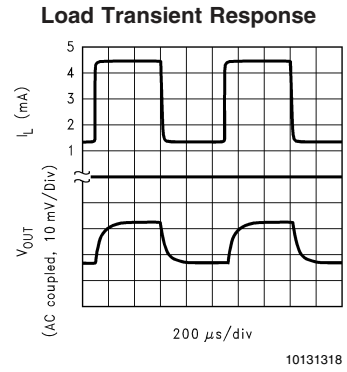
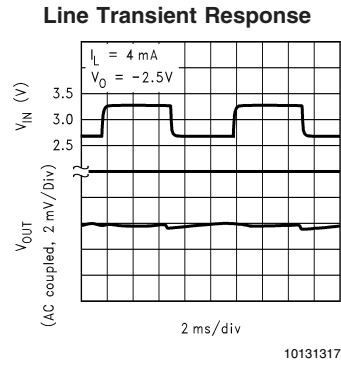

FIGURE 2. Functional Block Diagram

Device Description

The LM2787 is an inverting, regulated charge-pump power converter. It features low noise, small physical size, and is simple to use. It is an ideal solution for biasing GaAsFET devices such as power amplifier modules found in portable devices and cellular phones.

A switched capacitor charge-pump circuit is used to invert the input voltage V_{IN} to its corresponding negative value which is seen at V_{NEG} . This voltage is regulated by a low dropout linear regulator at V_{OUT} (Figure 2). The output voltage can be regulated anywhere from $-1.5V$ to $-5.2V$ and is determined by a pair of feedback resistors (see Setting the Output Voltage). The PSRR of the linear regulator reduces the output voltage ripple produced by the charge-pump inverter at the output V_{OUT} . The regulator also attenuates noise from the incoming supply due to its high PSRR.

Shutdown

The LM2787 features a logic-level shutdown feature. The function is active-low and will reduce the supply current to $0.05\mu A$ (typical) when engaged. When shutdown is active V_{OUT} and V_{NEG} are switched to ground.

Application Information

Setting the Output Voltage

The output voltage on the LM2787 is set by using a resistor divider between the output, the feedback pin, and an arbitrary voltage V_{ADJ} (Figure 2). V_{ADJ} can range from GND to any positive voltage up to V_{IN} . V_{ADJ} is usually chosen to be GND and should not be connected to a different voltage unless it is well regulated so the output will stay constant. The feedback pin is held at a constant voltage V_{FB} which equals $-1.2V$. The output voltage can be selected using the equation:

$$V_{OUT} = \frac{R_2}{R_1} (V_{FB} - V_{ADJ}) + V_{FB}$$

The current into the feedback pin I_{FB} is in the range of $10nA$ to $100nA$. Therefore using a value of $500k\Omega$ or smaller for R_1 should make this current of little concern when setting the output voltage. For best accuracy, use resistors with 1% or better tolerance.

Capacitor Selection

Selecting the right capacitors for your circuit is important. The capacitors affect the output resistance of the charge-pump, the output voltage ripple, and the overall dropout voltage ($V_{IN}-|V_{OUT}|$) of the circuit. The output resistance of the charge-pump inverter is:

$$R_{NEG} = R_{SW} + 4ESR_{C1} + ESR_{C2} + \frac{1}{f_{SW} \times C1}$$

The switching frequency is fixed at $260kHz$ and R_{SW} (the combined resistance of the internal switches) is typically

10Ω . It is clear from this equation that low ESR capacitors are desirable and that larger values of C_1 will further reduce the output resistance. The output resistance of the entire circuit (in dropout) is:

$$R_{OUT} = R_{NEG} + R_{regulator}$$

$R_{regulator}$ (the output impedance of the linear regulator) is approximately 10Ω . When the circuit is in regulation, the overall output resistance is equal to the linear regulator load regulation ($5mV/mA$). The dropout voltage is therefore affected by the capacitors used since it is simply defined as $I_{OUT} \times R_{OUT}$.

A larger value of capacitor and lower ESR for C_2 will lower the output voltage ripple of the charge-pump. This ripple will then be subject to the PSRR of the linear regulator and reduced at V_{OUT} .

In summation, larger value capacitors with lower ESR will give the lowest output noise and ripple. C_1 , C_2 , and C_3 should be $1.0\mu F$ minimum with less than 0.3Ω ESR. Larger values may be used for any or all capacitors. All capacitors should be either ceramic, surface-mount chip tantalum, or polymer electrolytic.

Output Noise and Ripple

Low output noise and output voltage ripple are two of the attractive features of the LM2787. Because they are small, the noise and ripple can be hard to measure accurately. Ground loop error between the circuit and the oscilloscope caused by the switching of the charge-pump produces ground currents in the probe wires. This causes sharp voltage spikes on the oscilloscope waveform. To reduce this error, measure the output directly at the output capacitor (C_3) and use the shortest wires possible. Also, do not use the ground lead on the probe. Take the tip cover off of the probe and touch the grounding ring of the probe directly to the output ground. This should give the most accurate reading of the actual output waveform.

Micro SMD Mounting

The micro SMD package requires specific mounting techniques which are detailed in National Semiconductor Application Note # 1112. Referring to the section **Surface Mount Technology (SMT) Assembly Considerations**, it should be noted that the pad style which must be used with the 8-pin package is the NSMD (non-solder mask defined) type.

For best results during assembly, alignment ordinals on the PC board may be used to facilitate placement of the micro SMD device.

Micro SMD Light Sensitivity

Exposing the micro SMD device to direct sunlight may cause misoperation of the device. Light sources such as Halogen lamps can also affect electrical performance if brought near the device.

The wavelengths which have the most detrimental effect are reds and infra-reds. The fluorescent lighting used inside of most buildings has very little effect on performance.

Physical Dimensions inches (millimeters)

unless otherwise noted

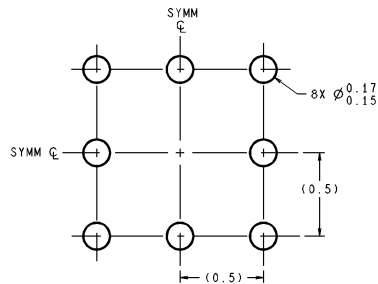

DIMENSIONS ARE IN MILLIMETERS

LAND PATTERN RECOMMENDATION

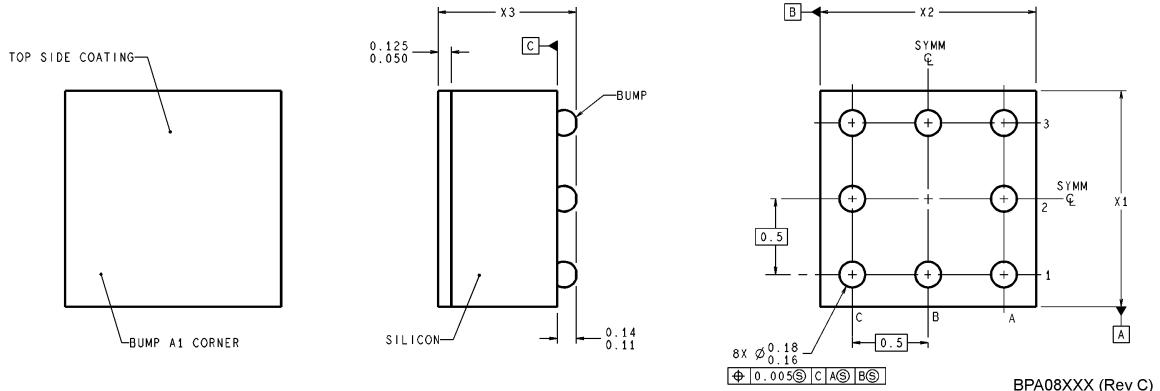

BPA08XXX (Rev C)

8-Bump micro SMD
NS Package Number BPA08CCB
For Ordering, Refer to Ordering Information Table
 $X_1 = 1.346$ $X_2 = 1.346$ $X_3 = 0.850$

LIFE SUPPORT POLICY

NATIONAL'S PRODUCTS ARE NOT AUTHORIZED FOR USE AS CRITICAL COMPONENTS IN LIFE SUPPORT DEVICES OR SYSTEMS WITHOUT THE EXPRESS WRITTEN APPROVAL OF THE PRESIDENT AND GENERAL COUNSEL OF NATIONAL SEMICONDUCTOR CORPORATION. As used herein:

1. Life support devices or systems are devices or systems which, (a) are intended for surgical implant into the body, or (b) support or sustain life, and whose failure to perform when properly used in accordance with instructions for use provided in the labeling, can be reasonably expected to result in a significant injury to the user.
2. A critical component is any component of a life support device or system whose failure to perform can be reasonably expected to cause the failure of the life support device or system, or to affect its safety or effectiveness.



National Semiconductor Corporation
Americas
Email: support@nsc.com

www.national.com

National Semiconductor Europe
Fax: +49 (0) 180-530 85 86
Email: europe.support@nsc.com
Deutsch Tel: +49 (0) 69 9508 6208
English Tel: +44 (0) 870 24 0 2171
Français Tel: +33 (0) 1 41 91 8790

National Semiconductor Asia Pacific Customer Response Group
Tel: 65-2544466
Fax: 65-2504466
Email: ap.support@nsc.com

National Semiconductor Japan Ltd.
Tel: 81-3-5639-7560
Fax: 81-3-5639-7507

www.s-manuals.com